



Aicube Care

Jintian Industrial Park, Huadong Town, Huadu District, Guangzhou City, Guangdong Province, China.
www.selaqua.com

Contact: Katie Peng
 Sales Manager
 M:+86 18620266308
 E: katie@selaqua.com

PRODUCT DETAILS

Type	Support Rails
Item Code	FS-600
Range	FIXED Grab Bar
Materials	1. Metal part constructed with super solid aluminum alloy. 2. The fixing kits and fasteners are made of stainless steel. 3. The base is with plastic top cover providing in different colors
Finish	Anozied Matt Silver color

Technical Details and Descriptions:

1. Wall mounted grab bar fixed with screws going through the base
2. Diameter 35mm . Length 600mm
3. Certified Weight loading 150kgs in the weakest point.

Standard and Warranty

Standard	ISO17966
Warranty	Expected service life of the shower grab is 10 years, provided that maintenance is carried out correctly. We makes a commitment to remedy material and manufacturing defects for a period of 3 years from the invoicing date.

Cleanning and Care Guide

1. The product is to be cleaned with hot water or a mild soapy cleaning agent.
2. We recommend that chalky deposits be removed from aluminum parts using a solution of 3:7 acetic acid: tap water. When the aluminum parts have been washed down with this solution, the parts must be wiped over with a damp cloth, wrung out in clear water. The product must be wiped down with a soft rag wrung out in clear water immediately after cleaning, as some materials may otherwise be discolored and stained, and the surface coating may deteriorate.

Warm Note: Do not use chlorine based, corrosive or abrasive cleaners as it may result in the surface being damaged.

IMAGE



TECHNICAL DRAWINGS

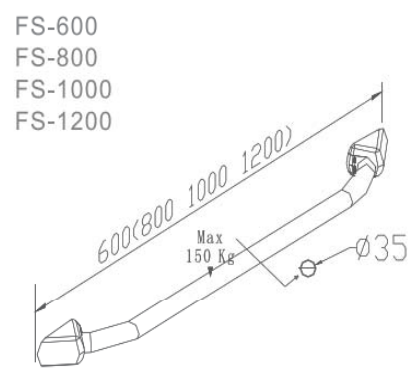

Toilet Grab Bar
 Wall Mounted
 Solid Metal Wall Fixing in stainless steel
 INCL. Stainless Steel Screws and Universal Wall Plugs
 Ergonomical Rail made of super high quality material
 Length:600mm(refer to above drawings)

Weight loading 150kgs certified.