

Aicube--Care with Love



Guangzhou SELAQUA Sanitary Ware Co., Ltd
Jintian Industrial Park, Huadong Town, Huadu District, Guangzhou City, Guangdong Province, China.
www.selaqua.com; www.aicubecare.com

Contact: Katie Peng
Sales Manager
M:+86 18620266308
E: katie@aicubecare.com

PRODUCT DETAILS	
Type	Basin holder
Item Code	XGB-B100
Range	Bathroom Accessories
Materials	1. Metal part constructed with super solid aluminum . 2. Basin holder in solid aluminium alloy 3. The fixing kits and fasteners are made of stainless steel.
Finish	Bright Chrome holder bracket
Technical Details and Descriptions:	
Wall mounted basin holder bracket, Height adjustable. Distance adjustable screw kits on the bracket, any basin can fit it. Certified Weight loading 150kgs for basin bracket	
Standard and Warranty	
Standard	ISO17966
Warranty	Expected service life of the shower seat is 10 years, provided that maintenance is carried out correctly. We makes a commitment to remedy material and manufacturing defects for a period of 3 years from the invoicing date.

Cleanning and Care Guide	
1. The product is to be cleaned with hot water or a mild soapy cleaning agent.	
2. We recommend that chalky deposits be removed from aluminum parts using a solution of 3:7 acetic acid: tap water. When the aluminum parts have been washed down with this solution, the parts must be wiped over with a damp cloth, wrung out in clear water. The product must be wiped down with a soft rag wrung out in clear water immediately after cleaning, as some materials may otherwise be discolored and stained, and the surface coating may deteriorate.	
Warm Note: Do not use chlorine based, corrosive or abrasive cleaners as it may result in the surface being damaged.	

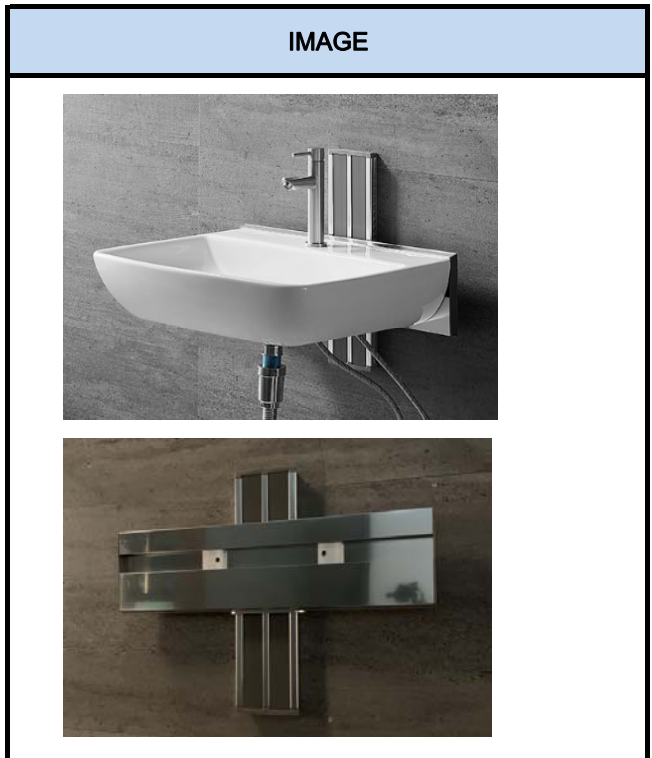

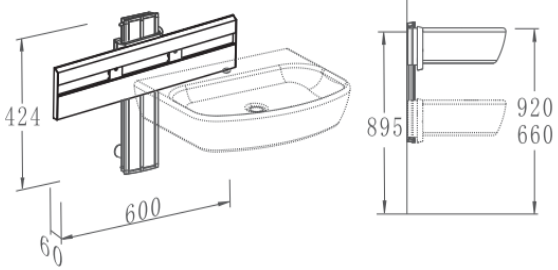
TECHNICAL DRAWINGS

<p>Basin Holder</p> <p>Wall Mounted . Height adjustable</p> <p>Solid Metal Wall Fixing</p> <p>INCL. Stainless Steel Screws and Universal Wall Plugs</p> <p>Wide-600mm, (refer to above drawings)</p> <p>Weight loading 150kgs certified for the holder bracket</p> <p>Carton Dimension:67X51X12CM. Gross Weight. 6.26kgs</p>